

Programmable Precision References

The LM431, A, B integrated circuits are three-terminal programmable shunt regulator diodes. These monolithic IC voltage references operate as a low temperature coefficient zener which is programmable from V_{ref} to 40 V with two external resistors, with a typical dynamic impedance of 0.2Ω . The characteristics of these references make them excellent replacements for zener diodes in many applications such as digital voltmeters, power supplies, and op amp circuitry. The 2.5 V reference makes it convenient to obtain a stable reference from 5.0 V logic supplies, and since the LM431, A, B operates as a shunt regulator, it can be used as either a positive or negative voltage reference.

Features

- Programmable Output Voltage to 40 V
- Voltage Reference Tolerance: $\pm 0.5\%$
- Low Dynamic Output Impedance, 0.2Ω Typical
- Cathode Current Range (Continuous)- 100 mA to 150 mA
- Equivalent Full-Range Temperature Coefficient of 50 ppm/ $^{\circ}\text{C}$ Typical
- Temperature Compensated for Operation over Full Rated Operating Temperature Range
- Low Output Noise Voltage
- Pb-Free Packages are Available
- ESD Tolerance 2000v
- Operating Temper Range $-40 \sim +85 \text{ }^{\circ}\text{C}$

MARKING DIAGRAMS

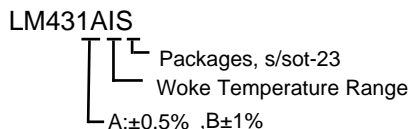

Marking code:

N1E:LM431A

N1F:LM431B

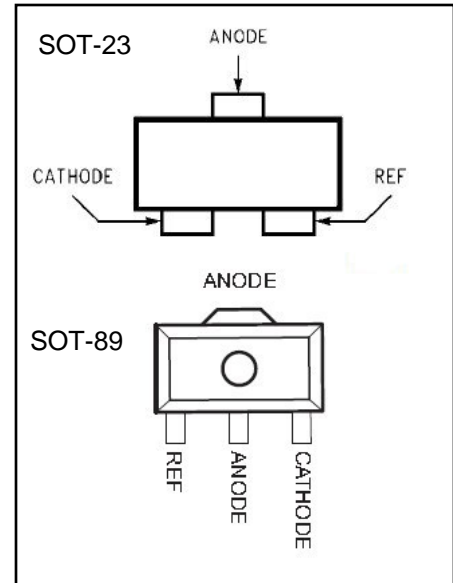

Symbol

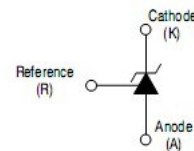

Representative Block Diagram

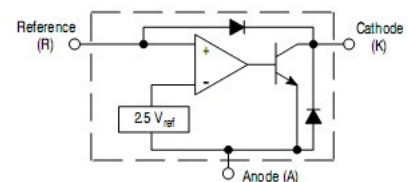

This device contains 12 active transistors.

MAXIMUM RATINGS (Full operating ambient temperature range applies, unless otherwise noted.)

Rating	Symbol	Value	Unit
Cathode to Anode Voltage	V_{KA}	42	V
Cathode Current Range, Continuous	I_K	-100 to +150	mA
Reference Input Current Range, Continuous	I_{ref}	0.05 to +10	mA
Operating Junction Temperature	T_J	0~150	°C
Operating Ambient Temperature Range	T_A	-40 to +85	°C
Storage Temperature Range	T_{stg}	-65 to +150	°C
Total Power Dissipation @ $T_A = 25^\circ\text{C}$ Derate above 25°C Ambient Temperature TO-92 Package ($\theta_{JA} = 178^\circ\text{C/W}$) SOT-23-3 Package ($\theta_{JA} = 625^\circ\text{C/W}$)	P_D	0.70 0.20	W
Total Power Dissipation @ $T_C = 25^\circ\text{C}$ Derate above 25°C Case Temperature D, LP Suffix Plastic Package P Suffix Plastic Package	P_D	1.5 3.0	W

Maximum ratings are those values beyond which device damage can occur. Maximum ratings applied to the device are individual stress limit values (not normal operating conditions) and are not valid simultaneously. If these limits are exceeded, device functional operation is not implied, damage may occur and reliability may be affected.

NOTE: ESD data available upon request.

RECOMMENDED OPERATING CONDITIONS

Condition	Symbol	Min	Max	Unit
Cathode to Anode Voltage	V_{KA}	V_{ref}	40	V
Cathode Current	I_K	0.5	100	mA

ELECTRICAL CHARACTERISTICS ($T_A = 25^\circ\text{C}$, unless otherwise noted.)

Parameter	Symbol	Min	Typ.	Max.	Unit	Test Conditions
Cathode Voltage	V_{KA}	V_{REF}	-	42	V	
Cathode Current	I_{KA}	-100	-	150	mA	
Reference Input Voltage	431C 431B 431A	V_{REF}	2.445 2.470 2.483	2.495 2.495 2.495	2.545 2.520 2.507	V $V_{KA} = V_{REF}, I_K = 10\text{mA}$
Deviation of reference Input Voltage Over temperature(note)	$\Delta V_{REF}/\Delta T$	-	3.0	17	mV	$V_{KA} = V_{REF}, I_K = 10\text{mA}$ $T_{min} \leq T_A \leq T_{max}$
Ratio of Change in Reference Input Voltage to the Change in Cathode Voltage	$\Delta V_{REF}/\Delta V_{KA}$	-	-1.4 -1.0	-2.7 -2.0	mV/V	$I_K = 10\text{mA}$ $\Delta V_{KA} = 10V \sim V_{REF}$ $\Delta V_{KA} = 36V \sim 10V$
Reference Input Current	I_{REF}	-	1.8	4	μA	$I_K = 10\text{mA}, R_1 = 10\text{K}\Omega, R_2 = \infty$
Deviation of reference Input Current Over Full Temperature Range	$\Delta I_{REF}/\Delta T$	-	0.4	1.2	μA	$I_K = 10\text{mA}, R_1 = 10\text{K}\Omega, R_2 = \infty$ $T_A = \text{Full Temperature}$
Minimum Cathode Current for Regulation	$I_{KA}(\text{min})$	-	0.5	1.0	mA	$V_{KA} = V_{REF}$
Off-State Cathode Current	$I_{KA}(\text{off})$	-	0.17	0.9	μA	$V_{KA} = 42\text{V}, V_{REF} = 0$
Dynamic Impedance	$ Z_{KA} $	-	0.27	0.5	Ω	$V_{KA} = V_{REF}, I_K = 1 \text{ to } 100\text{mA}, F \leq 1.0\text{KHz}$

2. The deviation parameter ΔV_{ref} is defined as the difference between the maximum and minimum values obtained over the full operating ambient temperature range that applies.

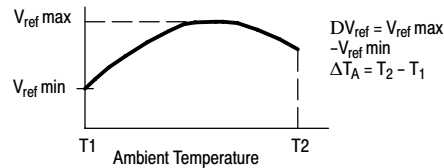

The average temperature coefficient of the reference input voltage, αV_{ref} is defined as:

$$V_{ref} \frac{\text{ppm}}{^\circ\text{C}} = \frac{\left(\frac{\Delta V_{ref}}{V_{ref} @ 25^\circ\text{C}} \right) \times 10^6}{\Delta T_A} = \frac{\Delta V_{ref} \times 10^6}{\Delta T_A (V_{ref} @ 25^\circ\text{C})}$$

αV_{ref} can be positive or negative depending on whether $V_{ref} \text{ Min}$ or $V_{ref} \text{ Max}$ occurs at the lower ambient temperature. (Refer to Figure 6.)

Example : $\Delta V_{ref} = 8.0 \text{ mV}$ and slope is positive,

$$V_{ref} @ 25^\circ\text{C} = 2.495 \text{ V}, \Delta T_A = 70^\circ\text{C}$$

$$\alpha V_{ref} = \frac{0.008 \times 10^6}{70 (2.495)} = 45.8 \text{ ppm}/^\circ\text{C}$$

3. The dynamic impedance Z_{KA} is defined as: $|Z_{KA}| = \frac{\Delta V_{KA}}{\Delta I_K}$. When the device is programmed with two external resistors, R_1 and R_2 , (refer to Figure 2) the total dynamic impedance of the circuit is defined as: $|Z_{KA}'| \approx |Z_{KA}| \left(1 + \frac{R_1}{R_2} \right)$

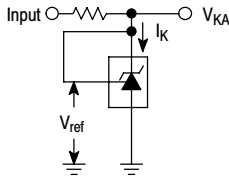

Figure 1. Test Circuit for $V_{KA} = V_{ref}$

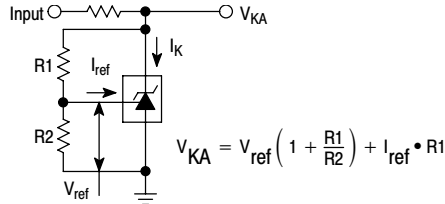

Figure 2. Test Circuit for $V_{KA} > V_{ref}$

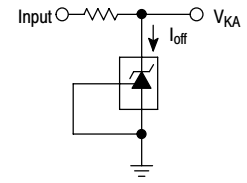

Figure 3. Test Circuit for I_{off}

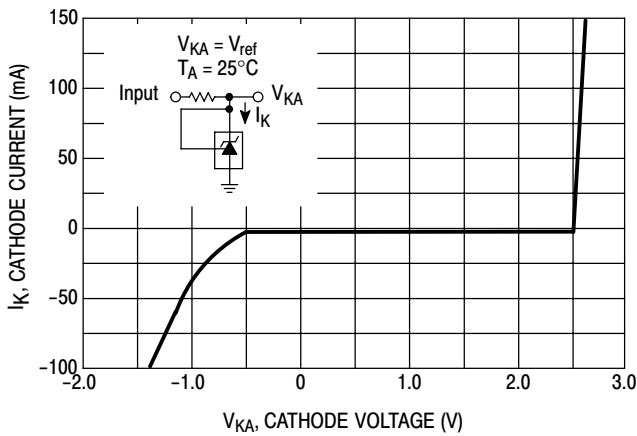

Figure 4. Cathode Current versus Cathode Voltage

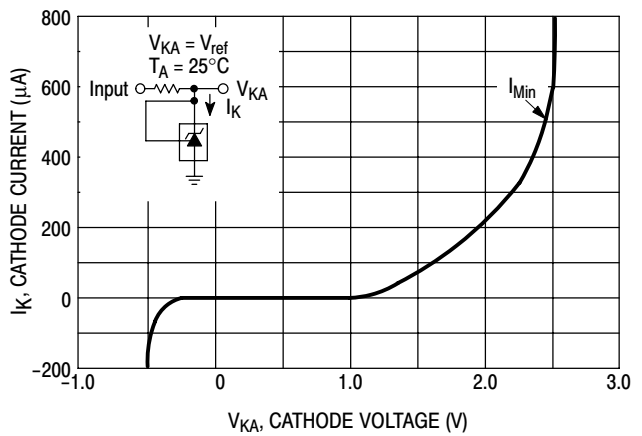

Figure 5. Cathode Current versus Cathode Voltage

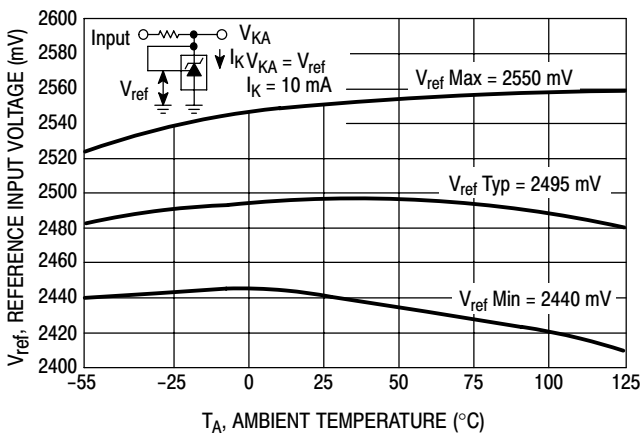

Figure 6. Reference Input Voltage versus Ambient Temperature

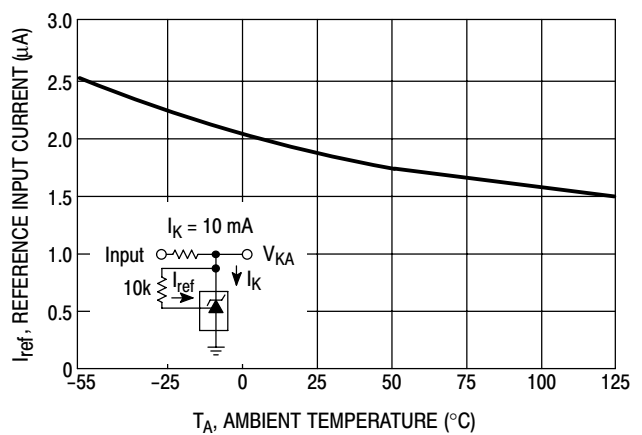

Figure 7. Reference Input Current versus Ambient Temperature